

HYDROPOOL SWIM SPA BAR TABLE – INSTALLATION INSTRUCTIONS

****IMPORTANT**** This table is not to be used for standing or diving. Risk of personal injury and swim spa damage with improper use

Tools For Installation – Note this can be installed by 1 person

- Box Level
- 1/2" Drill Bit
- 13/64" Drill Bit
- 5/16" Socket
- 6" extension bar (recommended)
- Tape Measure
- Power Drill
- Permanent Marker
- Painters Tape
- Robertson / Phillips Drill Bit

NOTE - Instructions outline installation on the front/back of the swim spa. For side mounting instructions, refer to the end of the manual.

Step 1: Tape the drill template on the center of the cabinet panel ensuring the top edge of the template is touching the bottom edge of the shell lip and that the template is level. This will ensure the swim spa table is 1" below the lip to allow for the cover straps to fit between the table and lip.

Mark both vertical edges of each support bracket onto the shell with marker (dotted line). This will help with install alignment.

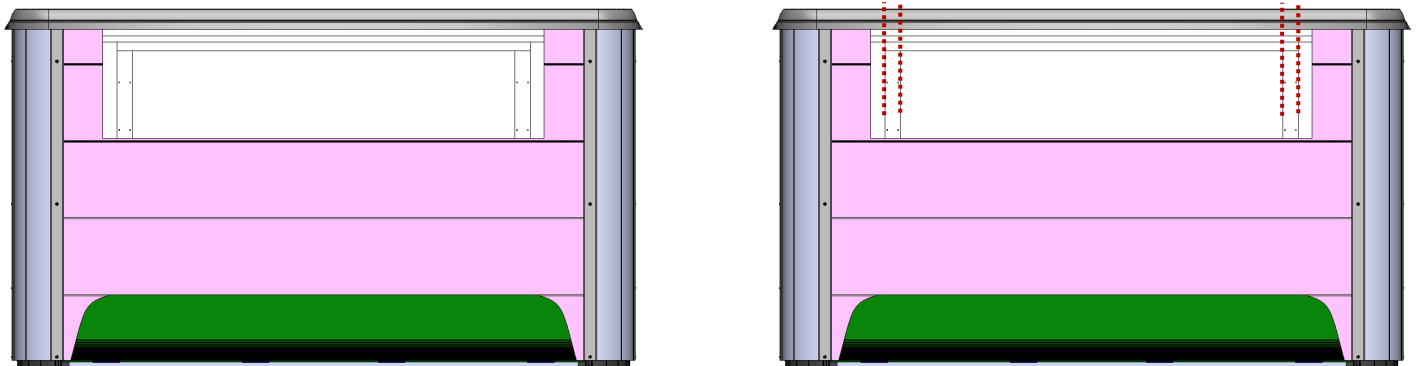

Step 2: Remove the gap lap strips, panel, and hardware. Set aside for later reassembly.

Step 3: Place 1X backing board between the frame roughly in the center of the marks on the shell. Using 2X black mending plates, position them centered on the backing board, with the mending plate edge flush (dotted line) to the frame edge. Fasten the mending plate using 8X #8-3/4" self drill screws to screw into the frame and 8X #8-3/4" wood screws to screw into the backing board. Outside edge between both backing boards should be ~64.50" for reference. Repeat step 3 on the opposite side.

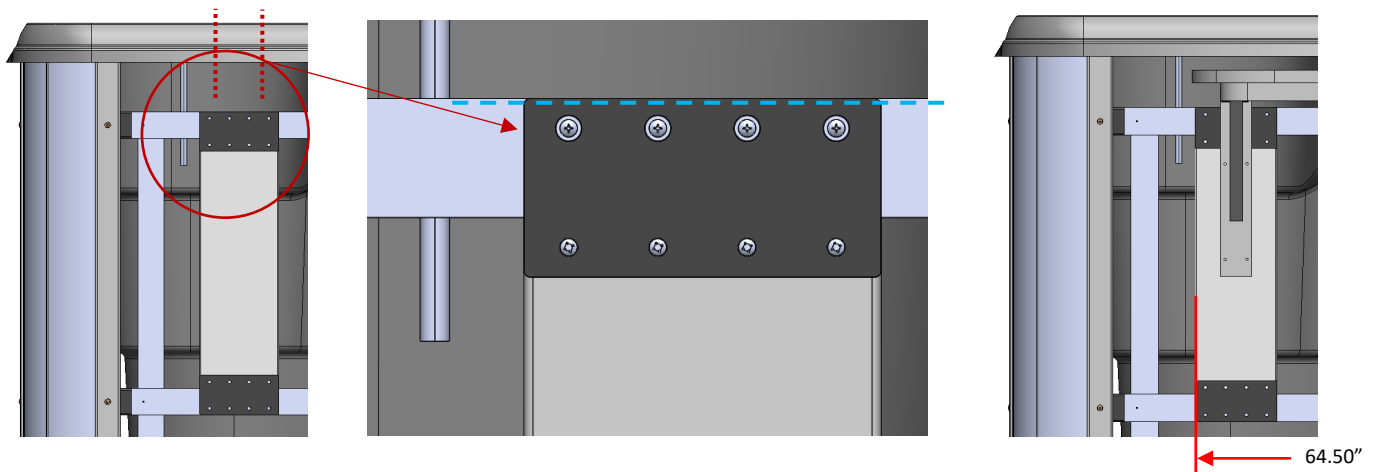

Step 4: With the panel off the swim spa and drill template taped on in Step 1, use a 13/64" drill bit to drill 8X pilot holes in the center of each of the 8X holes marked on the drill template. Then, using the 1/2" drill bit, drill out each of the 8X pilot holes making sure to drill through and clear away all the insulation foam.

Step 5: Place the panel and gap laps back onto the swim spa using the previously removed hardware ensuring the panel is centered with even gaps on each side. Use 8X of the 1" long spacers and place them through each of the 8X holes previously drilled.

NOTE: There is a Left-hand and Right-hand bracket. To prevent installing them on the incorrect sides, note the hole orientations below which are used to fasten the brackets to the underside of the tabletop.

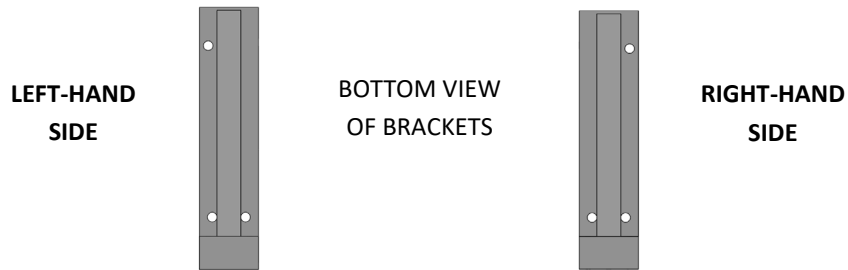

Step 6: Install the left-hand bracket using 4X #10-3" flanged hex heads and 4X #10 washers. Use a level to ensure its square before fastening the screws into the backing board using the 5/16" socket and extension. If the clearance hole is tight for the #10 hex head screw, you can use the 13/64" drill bit to drill out the through holes for a looser fit. Repeat step 6 for the right-hand bracket, using a level to ensure its square to the left-hand bracket before fully fastening.

Step 7: Position the tabletop onto the top of the brackets. You may need to slightly pull apart the 2X brackets to get the top to drop in. Using the supplied 6X Allen screws and hex key, screw the tabletop into the brackets on the underside of the table by hand tightening.

Side Mounting Instructions:

This bar table can also be installed on the sides of the swim spa following the same instructions outlined above through steps 1 to 7. However, due to the varying models and sizes of our Hydropool swim spas, as well as potential obstructions behind the cabinet panels which would prevent installation of the backing boards such as the metal frame and vertical gussets (see example below), it is up to the installer to ensure that there are no obstructions behind the drill locations that would prevent installation of the backing boards and that the vertical support bars on the backside of the cabinets will not be drilled through in the proposed table install location.

LEFT Location – Can be installed with no obstructions

RIGHT Location – Drill locations will hit the frame and gusset

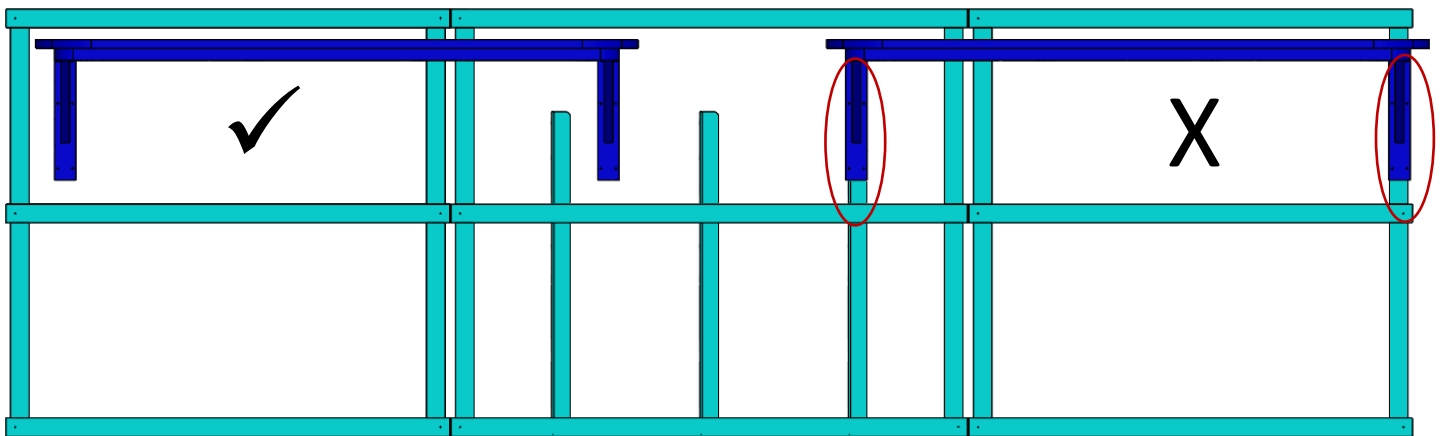

BILL OF MATERIALS					
ITEM	QTY	DESCRIPTION	ITEM	QTY	DESCRIPTION
1.	8	1" NYLON SPACER	6.	8	#10X3" FLANGED HEX HEAD WOOD SCREWS
2.	1	DRILL TEMPLATE	7.	8	#10 WASHERS
3.	2	BACKING BOARDS	8.	1	SWIM SPA BAR TABLETOP
4.	16	#8-3/4" WOOD SCREWS	9.	1	SWIM SPA BAR BRACKET LEFT HAND
5.	16	#8-3/4" SELF DRILL STEEL SCREWS	10.	1	SWIM SPA BAR BRACKET RIGHT HAND